

REGULATIONS FOR HAZARDOUS BIOLOGICAL AGENTS

OCCUPATIONAL HEALTH AND SAFETY ACT, 1993

REGULATIONS FOR HAZARDOUS BIOLOGICAL AGENTS

The Minister of Employment and Labour has under section 43 of the Occupational Health and Safety Act, 1993 (Act No. 85 of 1993) on the recommendation of the Advisory Council for Occupational Health and Safety, made the regulations in the Schedule.

SCHEDULE

No	Regulations
1	<p>Definitions</p> <p>In these Regulations any word or expression to which a meaning has been assigned in the Act shall have the meaning so assigned and, unless the context indicate otherwise –</p> <p>“biohazard” means potential source of harm caused by biological agent or toxin;</p> <p>“biological agent” means any micro-organism, cell or organic material with plant, animal or human origin, including any which have been genetically modified;</p> <p>“control measures” means measures that remove or reduce the exposure of persons at the workplace;</p> <p>“decontamination” means the procedure that eliminates or reduce biological agents to a level that does not cause harm with respect to the transmission of infection or other adverse effects;</p> <p>“diagnostic laboratory” means a workplace where all diagnostic or other screening procedures are performed on any biological agent or material;</p> <p>“disinfect” means to render non-viable virtually all recognised pathogenic micro-organisms, but not necessarily all microbial forms;</p> <p>“equipment” means a device designed to process HBA;</p> <p>“Facilities Regulations” means the Facilities Regulations promulgated by Government Notice No. R.2362 OF 5 October 1990 under section 43 of the Act;</p>

“General Administrative Regulations” means the General Administrative Regulations promulgated by Government Notice No. R.1449 of September 1996 under section 43 of the Act;

“HBA” means a hazardous biological agent which may cause an infection, allergy or toxicity, or otherwise create a hazard to human health, subdivided into the following groups:

- (a) Group 1 HBA are HBA that is unlikely to cause human disease;
- (b) Group 2 HBA are HBA that may cause human disease and be a hazard to exposed persons, which is unlikely to spread to the community and for which effective prophylaxis and treatment is usually available;
- (c) Group 3 HBA are HBA that may cause severe human disease, which presents a serious hazard to exposed persons and which may present a risk of spreading to the community, but for which effective prophylaxis and treatment is available;
- (d) Group 4 HBA are HBA that cause severe human disease and is a serious hazard to exposed persons and which may present a high risk of spreading to the community, but for which no effective prophylaxis and treatment is available.

“laboratory” a room or part of a building equipped for experimentation, research, testing or manufacture of drugs or chemicals or which may manipulate microbiological agents;

“micro-organisms” means microbiological entities, cellular or non-cellular, capable of replication or transferring genetic material;

“monitoring” means the planning and carrying out of the measurement programme and the recording of the results thereof;

“respiratory protective equipment” means a device which is worn over at least the mouth and nose to prevent the inhalation of airborne hazardous biological agents, and which conforms to a standard, acceptable to the Chief Inspector;

“safety equipment” means equipment which is designed to prevent exposure;

“standard precautions” means a synthesis of the major features of Universal Precautions (UP) and Body Substances Isolation (BSI) and applies to all persons coming into contact with potentially infected persons, animals or animal products and potentially contaminated blood and other fluids in the workplace and –

- (a) apply to:
 - i. all blood;
 - ii. all body fluids, secretions and excretions, except sweat, regardless of whether they contain visible blood or not;
 - iii. non-intact skin;
 - iv. mucous membrane; and
 - v. tissues; and
- (b) are designed to reduce the risk of transmission of HBA from both recognised and

	<p>unrecognised sources of infection in workplaces;</p> <p>“the Act” means the Occupational Health and Safety Act, 1993 (Act No. 85 of 1993).</p>
2	<p>Scope of application</p> <p>(1) Subject to subregulation (2), these Regulations shall apply to every employer and self-employed person at a workplace where –</p> <p>(a) HBA is produced, processed, used, handled, stored or transported; or</p> <p>(b) an incident, for which an indicative list is given in Annexure A to these Regulation occurs that does not involve a deliberate intention to work with a HBA but may result in persons being exposed to HBA in the performance of his or her work.</p> <p>(2) Regulations 8, 14, 15, 16 and 17 shall not apply to an employer or self-employed person at a workplace where the exposure is restricted to a Group I HBA.</p>
3	<p>Classification of biological agents</p> <ol style="list-style-type: none"> 1. The Biological Agents shall be assigned a classification of Group 1, Group 2, Group 3 or Group 4 according to hazard and categories of contaminant. 2. Where a biological agent has not been assigned a classification as contemplated in subregulation 1, the employer and self-employed person shall provisionally classify that agent in accordance with subregulation (3) below, having regard to the nature of the agent and the properties of which he or she may reasonably be expected to be aware. 3. When provisionally classifying a biological agent, the employer and self-employed person shall conduct a risk assessment and assign that agent to one of the groups and if there is doubt according to its level of risk of infection and as to which of two alternative groups would be most appropriate, the HBA shall be assigned to the higher of the two.
4	<p>Information and training</p> <p>(1) An employer, after consultation with the health and safety committee established for that section of the workplace, shall ensure that any employee at risk of being exposed or exposing others to HBA is comprehensively informed and trained, on both practical aspects and theoretical knowledge with regard to –</p> <ol style="list-style-type: none"> (a) the contents and scope of these regulations; (b) the potential risks to health caused by the exposure; (c) the measures to be taken by the employer to protect an employee against any risk of being exposed; (d) the importance of good housekeeping at the workplace and personal hygiene requirements; (e) the precautions to be taken by an employee to protect him- or herself against the

	<p>health associated with the exposure, including the wearing and use of protective clothing and respiratory protective equipment;</p> <ul style="list-style-type: none"> (f) the necessity, correct use, maintenance and potential of safety equipment, facilities and engineering control measures provided; (g) the necessity of medical surveillance; (h) the safety working procedures regarding the use, handling, labelling, and disposal of HBA at the workplace; (i) the procedures to be followed in the event of exposure, spillage, leakage, injury or any similar emergency situation, and decontaminating or disinfecting contaminated areas; and (j) the potential detrimental effect of exposure on the human reproductive process. <p>(2) The employer must ensure that the information and training referred to in subregulation (1) is provided before an employee is potentially exposed to HBA.</p> <p>(3) An employer or self-employed person shall give instructions in writing of the procedures contemplated in subregulation (1)(j) to the drivers of vehicles carrying the HBA.</p> <p>(4) Every employer and every self-employed person shall ensure that he or she or any person who in any manner assists him or her in the carrying out or conducting of his or her business has the necessary information and has undergone sufficient training in order for him or her to identify the potential risks and the precautions that should be taken.</p>
5	<p>Duties of persons who might be exposed to HBA</p> <ul style="list-style-type: none"> (1) Any person who is or might be exposed to HBA, shall obey any lawful instruction given by or on behalf of the employer or a self-employed person regarding – <ul style="list-style-type: none"> (a) the prevention of an uncontrolled release of an HBA; (b) the adherence to instructions regarding environmental and health practices, personal hygiene and good housekeeping; (c) the appropriate use of personal protective equipment and clothing as prescribed by these Regulations; (d) the appropriate use of personal samplers, when necessary, to measure personal exposure to airborne hazardous biological agents; (e) the disposal of materials containing HBA and the disinfection and decontamination of any site contaminated by an HBA; (f) the reporting during normal working hours for such medical examination or tests as contemplated in regulation 8(1); and (g) information and training as contemplated in regulation 4. (2) Any person shall immediately report to the employer, the health and safety representative or self-employed person any possible accidental exposure to a HBA at the workplace, and the employer or self-employed person shall ensure that such incident is investigated and recorded in accordance with regulation 9 of the General Administrative Regulations.
6	<p>Risk assessment by the employer or self-employed person</p> <ul style="list-style-type: none"> (1) An employer or a self-employed person contemplated in regulation 2 shall, after consultation with the relevant health and safety representative or relevant health and safety committee, conduct a risk assessment to determine if any exposure to HBA occurred.

	<p>(2) When making the risk assessment, as contemplated in subregulation 1, the employer or self-employed person shall take into account as a minimum the following matters –</p> <ul style="list-style-type: none"> (a) the nature of the HBA to which an employee may be exposed and the possible route of exposure; (b) where the HBA might be present and in what physical form it is likely to be; (c) the nature of the work and work processes; (d) current control measures in place, effectiveness of control measures, and any reasonable deterioration in, or failure thereof; and (e) what effects the HBA can have on an employee including pregnant and immunocompromised employee. <p>(3) An employer or a self-employed person shall conduct the risk assessment on the basis of all available information, including –</p> <ul style="list-style-type: none"> (a) Classification of the HBA into the relevant risk group, according to its level of risk of infection as contained in Annexure B (b) Recommendations from the manufacturer, supplier or a competent person regarding additional control measures necessary in order to protect the health of persons against such agents as a result of their work; (c) Information on diseases that may be contracted as a result of the activities at the workplace; (d) Potential allergenic or toxic effects that may result from the activities at the workplace; and (e) Knowledge of diseases from which employees might be suffering and which may be aggravated by conditions at the workplace. <p>(4) An employer shall review the assessment required by subregulation 1 —</p> <ul style="list-style-type: none"> (a) at intervals not exceeding two years; (b) forthwith, if there – <ul style="list-style-type: none"> i. Is a reason to suspect that the previous assessment is no longer valid; or ii. has been a change in a process involving a HBA; or iii. Has been a change in the methods, equipment or procedures in the use, handling, control or processing of HBA. <p>(5) The employer shall ensure that all employees, and the relevant health and safety committee are informed of the results of the risk assessment and may comment thereon.</p>
7	<p>Monitoring exposure at the workplace</p> <p>(1) An employer shall ensure that the exposure of employees to a HBA is monitored in accordance with a validated procedure, sufficiently sensitive and of proven effectiveness in any case, which is –</p> <ul style="list-style-type: none"> (a) requisite for ensuring the maintenance of adequate control of the exposure of employees to HBA as per risk assessment; or (b) otherwise requisite for protecting the health of employees.

	<p>(2) The monitoring referred to in paragraph (1) shall take place -</p> <ul style="list-style-type: none"> (a) at regular intervals; and (b) when any change occurs which may affect the exposure. <p>(3) The employer shall ensure that a suitable record of monitoring carried out for the purpose of this regulation is made and maintained and that record or a suitable summary thereof is kept -</p> <ul style="list-style-type: none"> (a) where the record is a representative of the personal exposures of identifiable employees, must be kept for at least 40 years; or (b) where an employee is required by regulation 8 to be under medical surveillance, an individual record of any monitoring carried out in accordance with this regulation shall be made, maintained and kept in respect of that employee.
8	<p>Medical Surveillance</p> <p>(1) An employer shall ensure that an employee is under medical surveillance if –</p> <ul style="list-style-type: none"> (a) the results of the assessment referred to in regulation 6 indicate that an employee might have been exposed to HBA; (b) the exposure of the employee to any HBA hazardous to his or her health is such that an identifiable disease or adverse effect to his or her health may be related to the exposure, there is a reasonable likelihood that the disease or effect may occur under the particular conditions of his or her work and there are techniques such as pre-clinical biomarkers, where appropriate, for detecting sensitisation to allergens or an inflammatory response associated with exposure to diagnose indications of the disease or the effect as far as is reasonably practicable; or (c) an occupational health practitioner recommends that the relevant employee should be under medical surveillance, in which case the employer may call upon an occupational medicine practitioner to ratify the appropriateness of such recommendation. <p>(2) In order to comply with the provisions of subregulation (1), the employer shall after extensive counselling and education offer the employee the opportunity to have –</p> <ul style="list-style-type: none"> (a) An initial health evaluation, which should be carried out by an occupational health practitioner immediately before or within 14 days after a person commences employment, where any exposure exists or might exist, which comprises – <ul style="list-style-type: none"> i. an evaluation of the employee’s medical and occupational history; ii. a physical examination: and iii. any biological tests and other appropriate medical tests or any other essential examination that is the opinion of the occupational health practitioner is desirable in order to enable the practitioner to do a proper evaluation. (b) Periodic medical examinations and tests in cases where a HBA is known to be capable of causing persistent or latent infections which – <ul style="list-style-type: none"> i. in the light of present knowledge, are undiagnosable, until signs or symptoms develop; ii. can have particularly long incubation periods; iii. can result in an illness which is recurrent in spite of treatment; and iv. are known to have serious long-term effects. (c) All tests and examinations as contemplated in paragraphs (a) and (b) shall be conducted according to a written medical protocol following current best

	<p>practices/guidelines national or international.</p> <p>(3) The employer shall, in accordance with regulation 8 of the General Administrative Regulations, investigate and record all incidents that result or might result in infections or the death of an employee.</p> <p>(4) All occupational health practitioners shall submit to the health and safety committee for approval a written protocol for procedures to be followed when dealing with abnormal results.</p>
9	<p>Records</p> <p>(1) An employer shall –</p> <ul style="list-style-type: none"> (a) keep records of all training, assessments, monitoring results and medical surveillance reports required by regulations 4, 6, 7 and 8 respectively: Provided that personal medical records shall be made available only to an occupational health practitioner; (b) subject to the provisions of paragraph (c), make the records contemplated in paragraph (a), excluding personal medical records, available for inspection by an inspector; (c) subject to the formal written consent of an employee, allow the representative of the employee to peruse the records with respect to that particular employee; (d) make the records of all risk assessments and monitoring results available for perusal by the health and safety representative or health and safety committee; (e) keep all records of risk assessments and monitoring results for a minimum period of 40 years; (f) keep all medical surveillance records for a minimum period of 40 years, and if the employer ceases activities, all those records shall be handed over to the relevant Chief Director: Provincial Operations (HPCSA guidelines); and (g) keep a record of the examinations and tests carried out in terms of regulation 12(b) and of any repairs resulting from these investigations and tests, which records shall be kept for at least five years. <p>(2) A self-employed person shall keep records of all risk assessments for a minimum period of 40 years, and if the self-employed person ceases activities, all those records shall be handed over to the relevant Chief Director: Provincial Operations.</p>
10	<p>Control of exposure to HBA</p> <p>(1) An employer and self-employed person shall ensure that–</p> <ul style="list-style-type: none"> (a) As a result of their activities, exposure of persons to HBA in the working environment is either prevented or, where this is not reasonably practicable, controlled such that exposure is highly improbable; and (b) The following standard precautions are implemented to reduce the risk of transmission of HBA from recognised and unrecognised sources of infection in a workplace:

	<ul style="list-style-type: none"> a. Hand washing b. Gloves c. Face or eye protection d. Protective clothing e. Safety equipment f. Environmental controls <p>(2) Where reasonably practicable, the employer or self-employed person shall control the exposure of persons to a HBA in the working environment by applying the following measures:</p> <ul style="list-style-type: none"> (a) limiting the amount of HBA used which might contaminate the working environment; (b) limiting the number of employees who might be exposed; (c) introducing measures for the control of exposure, which shall include any combination of the following contamination control concepts: <ul style="list-style-type: none"> i. separation of different infectious processes from each other and from people; ii. barrier isolation of process or agent; iii. local exhaust ventilation; iv. environmental air dilution or disinfection; v. positive static air pressure differential from infectious process to human occupied zones; vi. suppression of emissions of an airborne HBA; vii. access control to prevent unauthorised access; and viii. immediately accessible emergency personal or environmental disinfection. (d) Introducing appropriate work procedures that employees must follow where materials are handled, used, processes are carried out, or incidents might occur that could give rise to the exposure of an employee to HBA, and such procedures shall include documented instructions to ensure – <ul style="list-style-type: none"> i. the safe handling, use and disposal of HBA; ii. the proper use and maintenance of process machinery, installations, equipment, tools and local exhaust and general ventilation systems; iii. the regular cleaning of machinery and work areas by vacuum cleaners fitted with a suitable filtration that prevents contamination of the environment; iv. that a system is in place that identifies the need for early corrective action from changes to work procedures and practices. (e) displaying the biohazard sign shown in Annexure C to these Regulations and other relevant warning signs; and (f) specifying procedures for taking, handling and processing samples that might contain HBA.
11	<p>Personal protective equipment and facilities</p> <p>(1) If it is not reasonably practicable to ensure that the exposure of an employee is controlled as contemplated in regulation 10, the employer shall in the case of –</p> <ul style="list-style-type: none"> (a) airborne HBA, provide the employee with suitable respiratory protective equipment and protective clothing; and (b) HBA that can be absorbed through the skin, provide the employee with suitable

impermeable personal protective equipment.

- (2) Where respiratory protective equipment is provided, the employer shall ensure that –
 - (a) the relevant equipment is capable of preventing the exposure to the HBA concerned;
 - (b) the relevant equipment is correctly selected, fitted and properly used;
 - (c) information, instructions, training and supervision which would be necessary with regard to the use of the equipment are known to the employees; and
 - (d) the reusable equipment is kept in good condition and efficient working order.
- (3) An employer shall as far as is reasonably practicable –
 - (a) Not issue personal protective equipment which has been used to an employee unless it is capable of being decontaminated and sterilised prior to use;
 - (b) Provide separate containers or storage facilities for protective equipment and protective clothing when not in use; and
 - (c) Take steps to ensure that all protective equipment and protective clothing not in use are stored in a demarcated area with proper access control;
 - (d) Provide sufficient hazardous waste containers for disposal of used personal protective equipment.
- (4) An employer shall as far as is reasonably practicable, ensure that all contaminated personal protective clothing issued is cleaned and handled in accordance with the following procedures -
 - (a) where such clothing is cleaned on the premises of the employer, care shall be taken to prevent contamination during handling, transporting and cleaning;
 - (b) where clothing is sent off the premises to a contractor for cleaning purposes, the clothing shall be placed in impermeable, tightly sealed colour coded containers and such containers shall be clearly identified with a biohazard label as depicted in Annexure D to these Regulations as contaminated;
 - (c) where clothing from facilities, handling HBA Risk Group 3 and Risk Group 4 agents is sent off the premises for any purposes these must be first decontaminated; and
 - (d) ensure that the contractor as contemplated in subregulation (4)(b) is fully informed of the requirements of these Regulations and the precautions to be taken regarding the handling of contaminated clothing.
- (5) Subject to the provisions of subregulation (4)(b), an employer shall ensure that no person removes dirty or contaminated personal protective equipment and personal protective clothing from the premises: Provided that where contaminated personal protective equipment has to be disposed of, it shall be treated as HBA waste as contemplated in regulation 17.
- (6) Subject to the provisions of the Facilities Regulations an employer shall, where reasonably practicable, provide employees using personal protective equipment and clothing as contemplated in subregulation (1) with –
 - (a) Adequate washing facilities which are readily accessible and located in an area where the facilities will not become contaminated, in order to enable the employees to meet the standard of personal hygiene consistent with the adequate control of exposure, and to avoid the spread of HBA;
 - (b) Two separate lockers labelled “protective clothing” and “general clothing”

	<p>respectively, and ensure that the general and protective clothing is kept separately in the lockers concerned; and</p> <p>(c) Separate “clean” and “contaminated” change rooms if the employer uses or processes HBA to the extent that the HBA could endanger the health of persons outside the workplace.</p>
12	<p>Maintenance and monitoring of control measures and facilities.</p> <p>The employer shall ensure that -</p> <ul style="list-style-type: none"> a. documented risk-based protocols are developed, maintained and available at the workplace for all control measures, equipment and facilities provided in terms of regulations 6, 10 and 11, which include - <ul style="list-style-type: none"> i. performance parameters and minimum acceptance criteria; ii. performance monitoring methodology and intervals; iii. routine maintenance requirements, specifications and intervals; iv. relevant standards, regulations and manufacturer’s requirements; and v. minimum competency and training required to perform monitoring and maintenance activities. <p>(b) all control measures, equipment and facilities provided in terms of regulations 6, 10 and 11 are maintained in good working order and in accordance with the protocols referred to in (a) above;</p> <p>(c) thorough examination and tests of control measures, equipment and facilities provided in terms of regulations 6, 10 and 11 are carried out in accordance with the protocols referred to in (a) above, but at intervals not exceeding 24 months;</p> <p>(d) the protocols referred to in (a) above comply with any applicable guideline issued by the Chief Inspector.</p>
13	<p>Prohibitions</p> <p>(1) No person shall –</p> <ul style="list-style-type: none"> (a) use compressed air to remove HBA from any surface or person; (b) eat, drink, smoke, keep food or beverages or apply cosmetics in an HBA workplace or require or permit any other person to eat, drink, smoke, keep food or beverages or apply cosmetics in such a workplace; or (c) leave a controlled area without prior removal of protective or contaminated clothing and equipment. <p>(2) An employer or self-employed person shall cause a notice to be posted at a conspicuous place prohibiting the provision of (a), (b) and (c).</p>
14	<p>Labelling, packaging, transporting and storage</p> <p>An employer or self employed person shall, as far as is reasonably practicable, take steps to ensure that –</p>

	<ul style="list-style-type: none"> (a) all HBA under his or her control in storage, transit or being distributed, are properly contained and controlled to prevent the spread of contamination from the workplace; (b) Transport of HBA are performed with due consideration of the National Road Traffic Act, Chapter VIII, Transport of Dangerous Goods and Substances (Act 93 of 1996), and/or the International Air Transport Association (IATA) Infectious Substances Shipping Regulations; (c) Authorizations for the transport and storage of biological agents as required by the National Health Act (Act No 61 of 2003), Regulations relating to the Registration of Microbiological Laboratories and the Acquisition, Importation, Handling, Maintenance and Supply of Human Pathogens (Regulation 178), The Non-Proliferation of Weapons of Mass Destruction Act (Act 87 of 1993), Declaration of Certain Biological Goods and Technologies as Controlled Goods and Control Measures Applicable to Such Goods (Regulation no 19), The Animal Diseases Act (Act 35 of 1984), and the Genetically Modified Organisms Act (Act 15 of 1997), where applicable.
15	<p>Special measures for health and veterinary isolation facilities</p> <ul style="list-style-type: none"> (1) subject to the provisions of regulation 6, every employer and self-employed person shall, in the case of health and veterinary isolation facilities, take into account – <ul style="list-style-type: none"> (a) uncertainties about the presence of HBA in a patient or animal and the materials and specimens taken from them; (b) the hazard represented by HBA known or suspected to be present in a patient, animal, materials and specimens taken from them; and (c) the risks posed by the nature of the work. (2) An employer or self-employed person as contemplated in subregulation (1) shall ensure that the correct containment measures as indicated in Annexure D and E to these Regulations are selected for persons and animals in isolation facilities that are suspected of being infected with Group 3 or Group 4 HBA in order to minimise the risk of infecting others.
16	<p>Special measures for laboratories, animal rooms and industrial processes</p> <p>In the case of laboratories, animal rooms and industrial processes the employer or self-employed person contemplated in regulation 2 shall ensure that the containment measures required in –</p> <ul style="list-style-type: none"> (a) Annexure D and E are implemented in laboratories and in rooms for laboratory animals, including diagnostic laboratories, and in any rooms for laboratory animals that have been deliberately infected with Groups 2, 3 or 4 HBA or where laboratory animals are suspected of carrying such agents; (b) Annexure D and E are implemented in laboratories handling materials in respect of which uncertainty prevails about the presence of HBA that may cause human disease, but that do not have as their aim working with HBA as such: Provided that the containment measures that are required for Groups 2, 3 or 4 are implemented where it is known or suspected that it is necessary; (c) Annexure D and E are implemented where Groups 2, 3 or 4 HBA are used in industrial processes: Provided that where it has not been possible to carry out a conclusive assessment of HBA, but where the use envisaged might involve a serious health risk for persons, such activities may be carried out only in workplace where the containment

	measures correspond to the requirement for Groups 2, 3 or 4 HBA.
17	<p>Disposal of HBA</p> <p>An employer or self-employed person as contemplated in regulation 2 shall –</p> <ul style="list-style-type: none"> (a) lay down written procedures for appropriate decontamination and disinfection; (b) implement written procedures enabling infectious waste to be handled and disposed of without risk; (c) ensure that all fixtures and equipment including vehicles, re-usable containers and covers which have been in contact with HBA waste are disinfected and decontaminated after use in such a manner that it does not cause a hazard inside or outside the premises concerned; (d) ensure that all HBA waste that can cause exposure is disposed of only on sites specifically designated for this purpose in terms of the National Environmental Management Waste Act, 2008 (Act No. 59 of 2008), in such a manner that it does not cause a hazard inside or outside the site concerned; (e) ensure that all employees involved in the collection, transport and disposal of HBA waste and who may be exposed to that waste are provided with suitable personal protective equipment; and (f) ensure that if the services of a waste disposal contractor is used, a provision is incorporated into the contract stating that the contractor shall comply with the provisions of these Regulation.
18	<p>Hazardous Biological Agents Health and Safety Technical Committee</p> <p>1) The Chief Inspector must establish a HBA health and safety technical committee which must consist of-</p> <ul style="list-style-type: none"> a) a person who is to be the chairperson; b) two persons designated by the Chief Inspector from the employees of the Department of Labour; c) three persons designated by employer’s organisations to represent employers; d) three persons designated by employee’s organisations representing the federation of unions; e) one representative of each of the professional bodies, recognised by the Chief Inspector; f) one person from the field of HBA representing a higher educational institution; and <p>2) The Chief Inspector must appoint members of the HBA health and safety technical committee for a period that he or she may determine at the time of appointment: Provided that the Chief Inspector may after having afforded a member a reasonable opportunity to respond, discharge him or her at any time, for reasons that are fair and just, and appoint a new member in his or her place.</p> <p>3) The HBA health and safety Technical Committee must –</p> <ul style="list-style-type: none"> a) advise the Chief Inspector on HBA related matters, including but not limited to codes, standards and training requirements;

	<p>b) make recommendations and submit reports to the Chief Inspector regarding any matter to which these regulations relate;</p> <p>c) advise the Chief Inspector regarding any matter referred to the HBA health and safety technical committee by the Chief Inspector;</p> <p>d) perform any other function for the administration of a provision of these Regulations that may be requested by the Chief Inspector; and</p> <p>e) conduct its work in accordance with the instructions and rules of the conduct framed by the Chief Inspector.</p>
19	<p>Offenses and penalties</p> <p>Any person who contravenes or fails to comply with any provisions of regulations 3 to 17 shall be guilty of an offense and liable on conviction to a fine or to imprisonment for a period not exceeding 12 months and, in the case of a continuous offence, to an additional fine of R200 for each day on which the offence continues or additional imprisonment of one day for each day on which the offence continues: Provided that the period of such additional imprisonment shall in no case exceed 90 days.</p>
20	<p>Short title</p> <p>These Regulations shall be called Regulations for Hazardous Biological Agents.</p>
	<p style="text-align: center;">ANNEXURE A</p> <p style="text-align: center;">[Regulation 2(1)(b)]</p> <p style="text-align: center;">INDICATIVE LIST OF INCIDENTS</p> <p>Incidents or exposure during work –</p> <ul style="list-style-type: none"> (a) in a food production plant; (b) where there is contact with animals or products of animal origin; (c) in health care, including isolation and post-mortem units; (d) in clinical, veterinary and diagnostic laboratories; (e) in sewage purification installations; and (f) in a general workplace
	<p>ANNEXURE B</p> <p style="text-align: center;">HAZARDOUS BIOLOGICAL AGENTS GUIDELINES</p> <p style="text-align: center;"><u>CATEGORISATION OF BIOLOGICAL AGENTS ACCORDING TO HAZARD AND CATEGORIES OF CONTAINMENT</u></p> <p>INTRODUCTION</p> <ol style="list-style-type: none"> 1. The attached list must be read in conjunction with the <i>Hazardous Biological Agents</i>, and in particular regulation 3. 2. Agents listed are categorised on the basis of their ability to cause disease by infection.

3. In allocating agents to a hazard group in the list no account is taken of particular effects on those whose susceptibility to infection may be affected for one or other reason such as pre-existing disease, medication, compromised immunity, pregnancy or breastfeeding. Additional risk to such workers should be considered as part of the assessment required by the *Hazardous Biological Agents*.
4. Biological agents that have not been classified for inclusion into Group 2 to 4 in the list are not implicitly classified in Group 1.
5. If more than one species of any particular agents is known to be pathogenic to humans, the most prominent of these is generally named, together with the wider reference 'species' (spp) to indicate the fact that the other species of the same genus may be hazardous. If a whole genus is mentioned in this way, it is implicit that species and strains that are non pathogenic to humans are excluded.
6. When a strain is attenuated or has lost known virulence genes, the containment required by the classification of its parent strain need not necessarily apply, subject to assessment appropriate to the risk in the workplace, for example when such strain is used as a product or as part of a product for prophylactic or therapeutic purposes. (see 2)
7. All viruses that have been isolated in humans and that have not been assessed and allocated to a group in the list are to be classified in Group 2 as a minimum, except where there is evidence that they are unlikely to cause diseases in humans.
8. The requirements as to containment consequent upon the classification of parasites apply only to stages in the life cycle of the parasite in which it is liable to be infectious for humans.
9. The list also gives a separate indication where biological agents are capable of causing allergic or toxic reactions, where an effective vaccine is available.

The following notations identify the indications:

- A: Possible allergic effects;
- T: Toxic production;
- V: Effective vaccine available;
- NIV: National Institute of Virology.

The selection of control of measures for biological agents should take into account the fact that there is no exposure limits for them. Their ability to replicate and to infect at very small doses means that exposure may have to be reduced to levels that are diminishingly low.

For each activity the first consideration should be whether it could be carried out in a

way that involves exposure to a less harmful biological agent. This may be practicable, for example, in teaching and some types of research. If there is more than one way of carrying out the activity then the method carrying the least risk should be chosen.

If the least harmful alternative still involves exposure or potential exposure to biological agent, or the nature of the activity is such that there is no choice, and it is not reasonably practicable to prevent exposure by some other means, then exposure should be adequately controlled. All of the measures listed in Annexure E should be considered, and each should be used where and to the extent that –

- (a) it is applicable; and
- (b) the assessment carried but under regulation 6 shows that it will lead to a non-negligible reduction in risk.

Not all the listed measures will be required in every case. The assessment may indicate, for example, that a specific mode of transmission and route of infection is required, a susceptible host is needed, there is low prevalence of the infection in that particular activity, and that illness is easily treatable, leading to rapid and complete recovery.

In such a case the risk would be relatively low and the control measures required less stringent. Another factor that will determine whether controls are to be applied will be the extent to which the activity involves the handling or deliberate use of a biological agent, or exposure is incidental to the main purpose of the work. However, the level of risk should be the principal consideration – if the risk is sufficiently high and can be reduced by some of the listed measures, they should be applied in full.

Certain special measures are required in health and veterinary care facilities, laboratories, animal rooms and industrial processes to ensure that biological agents are not transmitted to workers or outside the controlled area. For laboratories, animal rooms and industrial processes rules are laid down for the derivation of containment level from the hazard classification of the agent, or from what is suspected about the possible presence of an agent. Laboratories screening for an agent which falls in Group 3 and 4, but which is not ordinarily expected to be present (for example a microbiological laboratory in a food factory screening for salmonella, with the possibility of finding *Salmonella typhi*), should achieve at least containment level 2, but switch to the appropriate higher level if the agent is found and if work is to continue with it. In a laboratory that does not deliberately work with biological agents, but where the presence of agents calling for containment levels 3 or 4 is nevertheless known or suspected, those containment levels should be used.

Agents with reduced virulence may be used at a lower than normal level of containment if the alternative has effectively changed their classification.

A biological agent that falls or is treated as falling into Hazard Group I may be a Group 3 genetically modified organism, because of environmental risks associated with it or because, though now unlikely to cause human disease, it is derived by genetic modifications from a pathogenic parent organism. In the latter case, the selection of containment measures appropriate to the agent's reduced virulence and corresponding group may be permitted. Where there is a mismatch, as in the case of genetically modified organism or biological agent which is non-hazardous to humans, but environmentally harmful, more stringent requirements should be followed.

	<p>Where the rules as set out lead to a particular containment level for an activity, all the measures appropriate to that should normally be used. Some selection may be done, however, to suit individual circumstances, provided that the risk is not increased by doing so.</p> <p>Regulation 11 sets out additional requirements in respect of personal protective equipment used to protect employees against biological agents. The object of these requirements is to prevent the equipment itself from acting as the means by which agents are transmitted, and they should be followed accordingly.</p> <p>Where workers are exposed to biological agents the information and instructions given to them, if applicable, should be set down in the form of written instructions, outlining procedures to be followed after a serious incident involving the handling of a biological agents as well as as the procedure for handling any Group 4 agent.</p> <p>If the nature of the workplace and the activity are such that employees may need instant access to this information, or where a reduction in risk may be expected by having the information conspicuously displayed in the workplace, it should also be set out on notices displayed in the workplace.</p> <p>BACTERRIA</p> <p>Key:</p> <p>A: allergic effects</p> <p>T: Toxic effects</p> <p>V: Vaccine available</p> <p>NIV: National Institute of Virology</p>
	<p style="text-align: center;">ANNEXURE C</p> <p style="text-align: center;">[Regulations 10 (2) (f), 11 (4) (b) and 14 (b)]</p> <p style="text-align: center;">BIO-HAZARD SIGN</p>

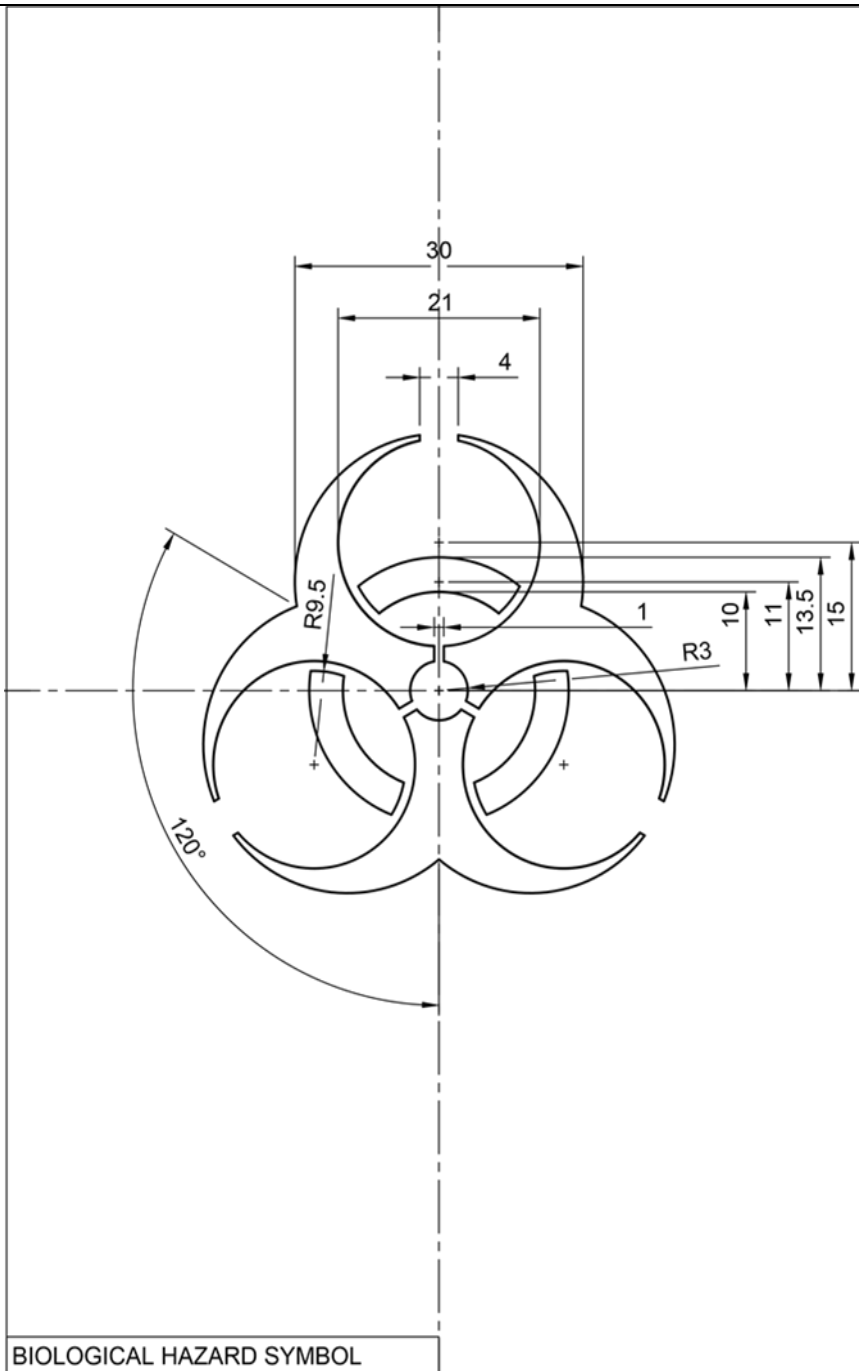

ANNEXURE D

[Regulations 15 (2), 16 (a) and (b)]

INDICATIONS CONCERNING CONTAINMENT MEASURES AND CONTAINMENT LEVELS FOR LABORATORIES AND INDUSTRIAL PROCESSES

For group 1 biological agents, including life-attenuated vaccines, no physical containment measures are prescribed below. For work with group 1 biological agents the principles of good occupational safety and hygiene should be observed.

Where hazardous biological agents can be transmitted through suspended aerosols over long

distances they are classified as airborne spread in the table below. Mechanism of transmission including contact, droplet and vector spread are considered as non-airborne spread below.

For group 2, 3 and 4 agents, it may be appropriate to select and combine containment requirements from different categories below on the basis of a risk assessment related to any particular process or part of process.

	Containment measures	Containment levels			
		2	3 (HBA Not Airborne Spread)	3 (HBA Airborne Spread)	4
		+ Mandatory for animal containment facilities ▶ Mandatory for industrial processes ⊙ Mandatory for Suite Laboratories			
1.	Viable microorganisms should be contained in a system which physically separates the process from the environment (closed system).	▶ Yes	▶ Yes		▶ Yes
2.	The workplace is to be separated from other areas of the same building.	No	Yes	Yes	Yes
3.	Exhaust and vent gasses, vapours or air should be treated so as to –	Minimise release	Prevent release	Prevent release	Prevent release
4.	Sample collection from a closed system, addition of materials to a closed system and transfer of viable microorganisms to another closed system, should be performed so as to –	▶ Minimise release	▶ Prevent release	▶ Prevent release	▶ Prevent release
5.	Bulk culture fluids should not be removed from the closed system unless	▶ Inactivated by validated means	▶ Inactivated by validated chemical or physical means	▶ Inactivated by validated chemical or physical means	▶ Inactivated by Validated chemical or physical means

		the viable microorganisms have been –					
6.	Equipment Seals should be designed so as to –	Minimise release	Prevent release	Prevent release	Prevent release		
7.	Closed and potentially contaminated systems should be located within controlled areas –	Optional	Yes	Yes	Yes, and purpose-built		
8.	biohazard signs should be posted (SANS 1186-1);	Yes	Yes	Yes	Yes		
9.	personnel should wear protective clothing;	Yes, work clothing	Yes	Yes	Yes, a complete change ⊙ positive pressure protective suits		
10.	decontamination and washing facilities should be provided for personnel (e.g. hand and eye wash, safety showers)	Yes	Yes	Yes ⊙ Suite decontamination at containment perimeter	Yes ⊙ Suite decontamination at containment perimeter		
11.	personnel should shower before leaving the controlled area;	No	Optional	Optional + Yes	Yes		
12.	effluent from sinks and showers should be collected and inactivated before release;	No	Optional	+ Yes	Yes		
13.	the controlled area should be adequately ventilated to minimise air contamination;	Optional	Optional	Yes	Yes		
14.	the controlled area should be maintained at an air pressure negative to atmosphere;	No	Optional	Yes	Yes		
15.	air supplied the controlled area should be HEPA	No	Optional	Optional ▶ Prevent	Yes		

		filtered;			backflow		
16.	all air extracted from the controlled area should be HEPA filtered;	No	Optional	Yes	Yes	Yes (Double HEPA Filtered)	
17.	the controlled area should be designed to contain spillage of the entire contents of closed system;	Optional	Yes	Yes	Yes	Yes	
18.	the controlled area should be sealable to permit fumigation.	No	Optional	Optional + Yes	Optional + Yes	Yes	
19.	Effluent treatment before final discharge.	Inactivated by validated means	Inactivated by validated chemical or physical means	Inactivated by validated chemical or physical means	Inactivated by validated physical means	Inactivated by validated physical means	
20.	Access is to be restricted to authorised persons only.	Yes	Yes	Yes, via air-lock	Yes, via air-lock key procedure	Yes, via air-lock key procedure	
21.	The workplace is to be sealable to permit disinfection.	No	Yes	Yes	Yes	Yes	
22.	Specified disinfection procedure.	Yes	Yes	Yes	Yes	Yes	
23.	The workplace is to be maintained at an air pressure negative to atmosphere.	No	Yes	Yes	Yes	Yes	
24.	Efficient vector control, e.g. rodents and insects.	Recommended + Yes	Recommended + Yes	Yes	Yes	Yes	
25.	Surfaces impervious to water and easy to clean.	Yes, for bench	Yes, for bench and floor (and walls for animal containment)	Yes	Yes, for bench, floor, walls and ceiling	Yes, for bench, floor, walls and ceiling	
26.	Surfaces resistant to acids, alkalis, solvents, disinfectants.	Yes, for bench	Yes, for bench and floor (and walls for animal containment)	Yes	Yes, for bench, floor, walls and ceiling	Yes, for bench, floor, walls and ceiling	
27.	Safe and secure storage of	Yes	Yes	Yes	Yes, secure storage	Yes, secure storage	

		biological agents.					
28.	An observation window, or alternative, is to be present, so that occupants can be seen.	No	Yes	Yes	Yes		
29.	A laboratory is to contain its own equipment.	No	Yes, so far as is reasonably practicable	Yes	Yes		
30.	Infected material, including any animal, is to be handled in a safety cabinet or isolator or other suitable containment.	Yes, where aerosol produced	Yes, where aerosol produced	Yes	Yes		
31.	Incinerator for disposal of animal carcasses.	Accessible service	Accessible service	Yes	Yes, on site		